



Applicative characteristics

- The PC67 displacement transducer was developed to guarantee a high protection level (IP67) in applications under harsh conditions and outdoors, where it may be necessary to work in the presence of dust, dirt, or liquids (not in prolonged immersion).
- The robust structure of the PC series has been improved thanks to a sealing system (patent pending) that makes it extremely reliable.
- Ideal for mobile hydraulic applications, on agricultural machines, earth-moving equipment and utility vehicles.

TECHNICAL DATA

Useful electrical stroke (C.E.U.)	50/100/130/150/175/200/225/275/300/360/375/400/450/500/600/750
Independent linearity (within C.E.U.)	± 0.05%
Resolution	Infinite
Repeatability	0.01 mm
Electrical connection	4 pole M12 connector
Protection	IP67 (use M12 4-pin female connector with IP67 protection level or higher)
Life (NOT for prolonged immersion)	> 25x10 ⁹ m strokes, or > 100x10 ⁶ maneuvers, whichever is less (within C.E.U.)
Displacement speed	Standard ≤ 3 m/s max ≤ 5 m/s
Displacement force	≤ 30N (breakaway force ≤ 35N)
Vibrations	5...2000Hz, Amax = 0.75 mm amax. = 20 g
Shock	50 g, 11ms.
Tolerance on resistance	± 20%
Recommended cursor current	< 0.1 μA
Maximum cursor current	10mA
Maximum applicable voltage	60V
Electrical isolation	>100MΩ at 500V~, 1bar, 2s
Dielectric strength	< 100μA at 500V~, 50Hz, 2s, 1bar
Dissipation at 40°C (0W at 120°C)	3W
Temperature Coefficient of the resistance	-200...+200 ppm/°C typic
Actual Temperature Coefficient of the output voltage	≤ 5 ppm/°C typic
Working temperature	-30...+100°C
Storage temperature	-50...+120°C
Case material	Anodised aluminium
Control rod material	C45 steel, chromium plated 20 μm
Mounting method	2 selfloading and selfaligning ball-joints

MECHANICAL DIMENSIONS

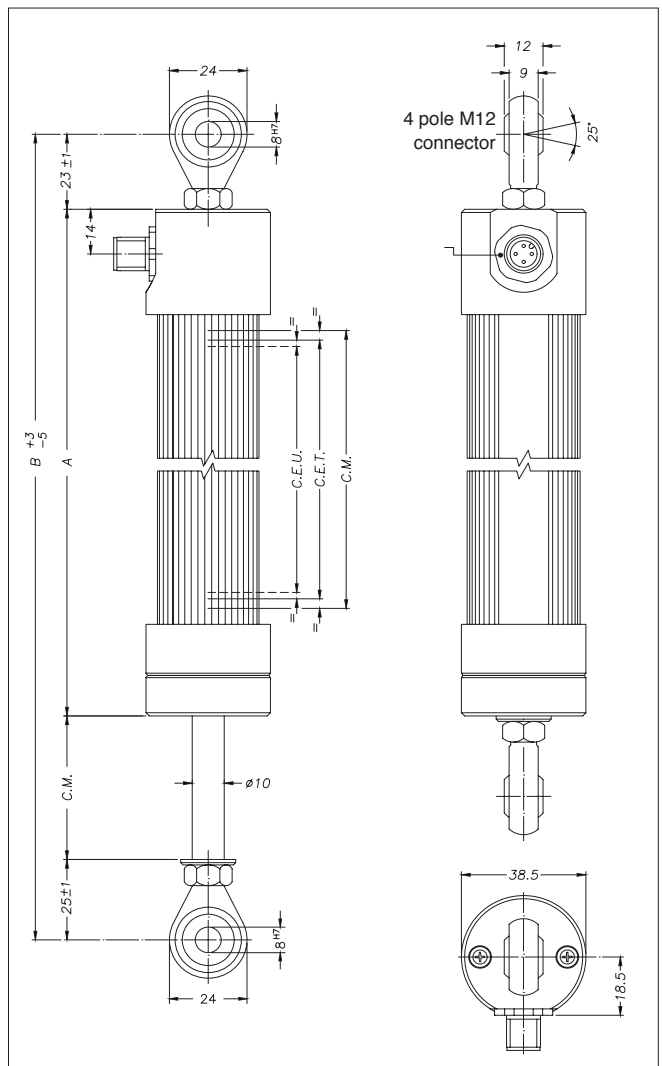

Important: all the data reported in the catalogue (linearity, lifetime, temperature coefficient) are valid for a sensor utilization as a ratiometric device with a max current across the cursor $I_c \leq 0.1 \mu A$.

